

Spicer® Tandem Axles

SPICER®



Illustrated Parts List

Spicer® Single Reduction 34,000 - 45,000 lbs

AXIP-0089

November 2004

TABLE OF CONTENTS

Spicer Axle Parts Book	2	Axle Housing & Axle Shafts	19
Forward Tandem Axle		Ring Gear and Pinion Identification .	21
Differential Carrier	3	Gear Sets	23
DS340 & DS380 Models		Input and Output Yokes	25
w/2-Speed Differential Carriers . . .	11	Pinion Bearing Spacers	26
Rear Tandem Axle		Power Divider Conversion Kit	27
Differential Carrier	12	Helical Gear Conversion Kit #113561	28
Differential Lockout (Forward Axle)		Differential Carrier Assembly	29
Current Production Model16	Yoke Selection Guide	30
Non-Current Production Model17	Wheel Differential Kits	31

Spicer Axle Parts Book

J&K Corporation, Axle & Brake Division presents this Parts Book as an aid in the identification and procurement of replacement parts for J&K Axles. The information included covers the differential carrier assembly, axle housing, axle shafts, shift system and special-designed parts kits and assemblies.

Exploded views are used to illustrate the parts and show their relationship to other parts on the carrier. Each part is identified by an item number, which in turn, leads to a list containing part name and part number.

For convenience, part numbers have been included for all pieces of the carrier assembly. However, some of these parts, such as differential carrier and caps, are serviced only in kits or assemblies. Part numbers are for your reference only. Those parts not serviced separately are identified with NSS.

Genuine Spicer Parts.

When you buy genuine J&K replacement parts, you receive the same high quality and exacting tolerances you find in the original axle components.

Only genuine J&K parts have the latest J&K engineering improvements and assure equal or better performance than the original parts.

And J&K backs you up with a responsive and capable service organization located strategically to provide you with emergency parts and service when you need them.

Insist on J&K quality. Use genuine J&K replacement parts.

Abbreviations

AR-As Required: Parts that vary in quantity with each axle. Example: shims.

NSS-Not Serviced Separately: Items which can only be purchased in sets, kit form or service assemblies. Example: ring gear sets.

RH/LH-Right Hand/Left Hand: Determined as viewed from behind the vehicle looking forward.

“RTV”-Gasket Compound: Formed-in-place gasket sealer. It is recommended for use on all surfaces requiring a gasket.

Spicer Parts Kits

J&K Parts Kits give you an economical, convenient way to stock J&K replacement parts. They contain all the parts you need to do a complete professional job of overhauling or repairing your J&K axle. And you have only one part number in one easily stored package to order, stock, identify, and satisfy your customers' needs.

Symbols:

This symbol is used throughout this book to identify parts included in major kits.

- * Carrier Basic Overhaul Kit
- Bearing Kit

Ordering Spicer Axle Parts

Place all your parts orders through your truck dealer or manufacturer (OEM). Do not order parts directly from J&K Corporation, Axle & Brake Division.

How to use this Parts Book

1. Refer to table of contents on opposite page for axle type, model or series, and page number.
2. Turn to the page that applies to the axle in question.
3. Locate the desired part in the exploded illustration and note Item No. This Item No. will lead you to the part name and number.
4. Refer to the related Parts Listing and locate the same Item No. and the name. If more than one part number is listed, refer to the axle model listings at top of list and select the part number that applies to the axle being serviced.

Axle Model Coverage:

This publication covers single reduction highway tandems (34,000-45,000 lbs.):

Forward Tandem Axle	Rear Tandem Axle
34DS	34RS
38DS	38RS
DS340	RS340
DS380(P)	RS380
DS400-P	RS400
DS341	RS341
DS381 (P)	RS381
DS401-P	RS401
DS341	RS341
DS402(P)	RS402
DS451-P	RS451

PLEASE REVIEW THESE NOTES PRIOR TO USING THIS PUBLICATION!

During the 4th Quarter of 1990, J&K began using new seals and yoke & slingers on models covered in this publication. The new seals and slingers are noticeably different from the current seals and will affect interchangeability. Before replacing seals or yoke & slingers, please refer to information on the top of page 25.

This publication has been designed to help you service highway tandem models built since 1958. Please note the column heads at the top of each parts list. The current models appear first, followed by earlier models.

Model changes were made to the current production models effective April 6, 1989 (96th day of 1989). Quick identification can be made by checking the carrier casting number on the rear tandem (127045 or 128109).

From 1972 until May 1978, DS340 and DS380 tandems were built with 2-Speed differential carriers. Special instructions and parts list for these models can be found on page 11.

Forward Tandem Axle Differential Carrier

Single Reduction

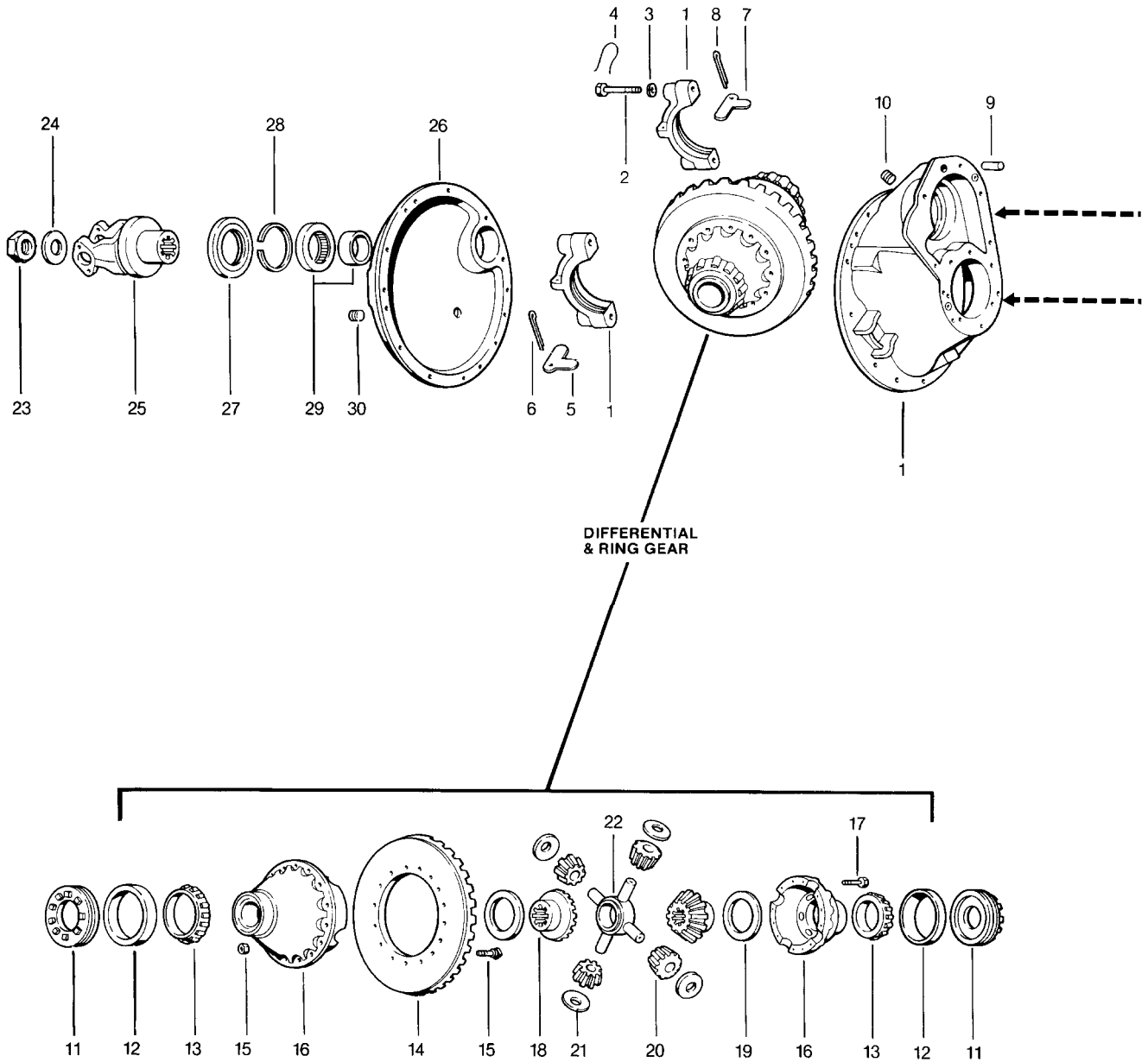

Forward Tandem Axle Differential Carrier

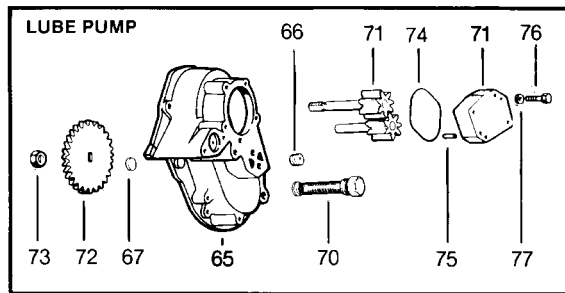
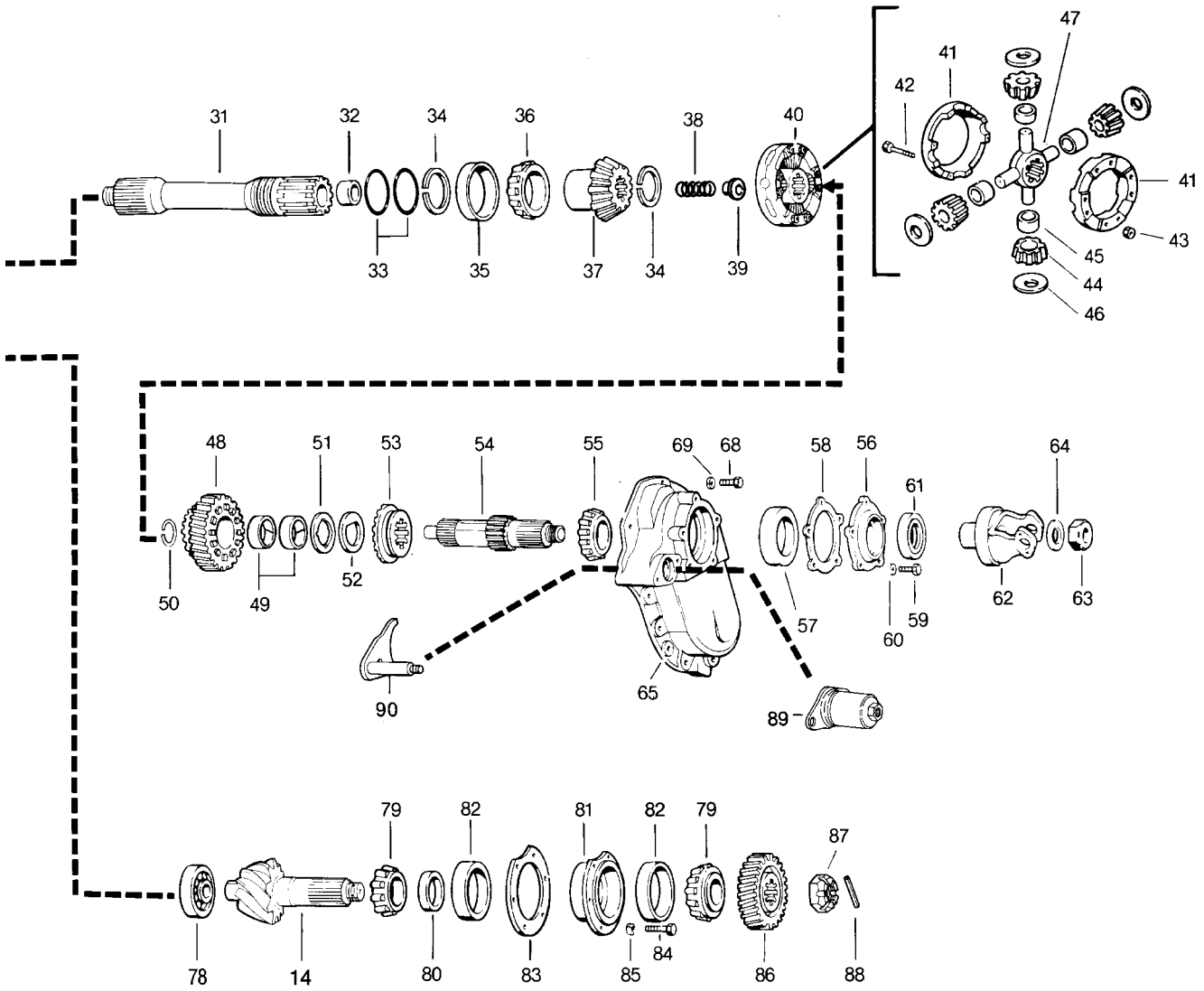

Forward Tandem Axle Differential Carrier

Item No.	Part Name	Qty Per Axle	DS341, DS402(P), DS451-P Built After 4-6-89	DS381(P), DS402(P), DS401-P, DS451-P, Built Before 4-6-89	DS340, DS380(P), DS400-P NOTE 1	34DS 38DS
	BASIC OVERHAUL KIT (Contents identified with *)	1	124487*	114399*	110593*	110560*
	BEARING KIT (Contents identified with •)	1	211222•	114394•	106845•	99044•
1	Diff. Carrier & Bearing Caps Carrier Casting No. (NSS) 115690 includes Items 2-4,9-10 120923,120924 include Items 2-4, 9-10, 35-37	1	115690 128107	115690 128107	120924 128107 NOTE 2	120923 128107 NOTE 2
2	Bearing Cap Screw	4	127179	127179	127179	127179
3	Flat Washer	4	26772	26772	26772	26772
4	Lockwire	4			90538	90538
5	Bearing Adjuster Lock (RH)	1	14275	14275	14275	14275
6	Cotter Pin (RH)	1	90876	90876	90876	90876
7	Bearing Adjuster Lock (LH)	1	13377	13377	13377	13377
8	Cotter Pin (LH)	1	90873	90873	90873	90873
9	Carrier Cover Dowel Pin	2	7641	7641	7641	7641
10	Filler Plug	1	90325	90325	90325	90325
11	Diff. Bearing Adjuster (RH)	1	31562	31562	31562	31562
	Diff. Bearing Adjuster (LH)	1	110243	110243	27842	27842
12	Diff. Bearing Cup (RH)	1	90943*•	90943*•	90943*•	90943*•
	Diff. Bearing Cup (LH)	1	9803*•	9803*•	9803*•	9803*•
13	Diff. Bearing Cone (RH)	1	6082*•	6082*•	6082*•	6082*•
	Diff. Bearing Cone (LH)	1	27813*•	27813*•	27813*•	27813*•
14	RING GEAR & DRIVE PINION SET Includes Item 15			Matched Parts; see separate listing on page 21		
15	RING GEAR BOLT & NUT KIT (5/8")	1	70745	70745	70745	70745
	Bolt	16	67586	67586	67586	67586
	Nut	16	60600	60600	60600	60600
	RING GEAR BOLT & NUT KIT (1/2")	1				69957
	Bolt	16				69117
	Nut	16				67592
	WHEEL DIFF. CASE KIT					
	Ratios 308 & 3.25	1	212202			
	Ratios 3.36-5.29	1	106397	106397	106397	
	Ratios 5.57-7.17 Includes Items 16,17 & 110243 adjuster	1	124374	124374	124374	
	12" O.D. -1/2" bolt Flanged Half 91114	1				96794
	11-1/2" O.D. -1/2" bolt Flanged Half 91116	1				96795
	5/8" bolt Flanged Half 88677	1				124374

Forward Tandem Axle Differential Carrier

Item No.	Part Name	Qty Per Axle	DS341, DS402(P), DS451-P Built After 4-6-89	DS381(P), DS402(P), DS401-P, DS451-P, Built Before 4-6-89	DS340, DS380(P), DS400-P NOTE 1	34DS 38DS
16	Diff. Case (Plain Half) (NSS)	1	210017	210017	210017	210017
	Diff. Case (Flanged Half) (NSS)	1				
	Ratios 3.08 & 3.25		127823			
	Ratios 3.36-5.29		103865	103865	103865	
	Ratios 5.57-7.17		88677	88677	88677	
17	Diff. Case Cap Screw	12	96271	96271	96271	96271
	WHEEL DIFF. SIDE GEAR, PINION KIT Includes Items 18-22	1				
	Models: 34,340,341		114469	114469	98850	98850
	38,380,381,402		114470	114470	85358	85358
	400,401,451		98853	98853	98853	
WHEEL DIFF. KIT LESS SIDE GEARS Includes Items 19-22	1	118748	118748	118748	118748	
18	Diff, Side Gear	2				
	Models: 34, 340, 341		110525	110525	37072	37072
	38,380,381,402		110527	110527	37069	37069
	400,401,451		85486	85486	85486	
19	Side Gear Thrust Washer	2	27827*	27827*	27827*	27827*
20	Side Pinion 104139 replaces 37071	4	104139	104139	104139	104139
21	Side Pinion Thrust Washer	4	27810*	27810*	27810*	27810*
22	Spider	1	38289	38289	38289	38289
23	Output Shaft Nut	1	95205	95205	95205	95205
24	Flat Washer	1	4327*	4327*	4327*	4327*
25	Output Yoke	1	SEE INFORMATION AND CHART ON page 25.			
26	Axle Housing Cover Assy Includes Items 27-30 (Casting# 127708)	1				
	Cover (127781 NSS)		107320	107320		
	3/4" (Cover 127874)				75336	75336
	1" (Cover 77749 NSS)					77750
	Rear Bearing Retaining Washer Not illustrated	1			46583*	46583*
27	Output Shaft Oil Seal	NOTE 9 1	127720*•	127720*•	127720*•	127720*•
28	Bearing Snap Ring	1	45516*	45516*	45516*	45516*
29	Output Shaft Bearing & Sleeve Assy		46584	46584	46584	46584
	Inner Bearing Race	1	118789*•	118789*•	118789*•	118789*•
	Outer Bearing Race	1	118790*•	118790*•	118790*•	118790*•
30	Magnetic Filler Plug					
	3/4"	1			54254	54254
	1"	1	75130	75130		75130
	1" Optional		77944	77944		
	Hole Plug	1	90898	90898		

Forward Tandem Axle Differential Carrier

Item No.	Part Name	Qty Per Axle	DS341, DS402(P), DS451-P Built After 4-6-89	DS381(P), DS402(P), DS401-P, DS451-P, Built Before 4-6-89	DS340, DS380(P), DS400-P NOTE 1	34DS 38DS
31	OUTPUT SHAFT, NUT & BUSHING KIT Includes Items 23, 32-33; 115123 also includes Items 38-39	1	115123	115123	98603 NOTE 3	98603 NOTE 3
	Shaft (NSS) 34 splines, 1.750" dia.		110818	110818		
	Shaft (NSS) 10 splines, 1.750" dia.				85441	85441
32	Output Shaft Bushing	1	48922*	48922*	48922*	48922*
33	Output Shaft "O" Ring	2	46526*	46526*	46526*	46526*
34	Side Gear Snap Ring	2	85994*	85994*	85994*	85994* NOTE 4
35	Output Shaft Bearing Cup (Inner)	1	110811*•	110811*•	51232*•	51232*•
36	Output Shaft Bearing Cone (Inner)	1	110812*•	110812*•	51233*•	51233*•
37	Output Shaft Side Gear	1	110810	110810	85436	85909
38	Output Shaft Spring	1	51238			
39	Output Shaft Spring Thrust Bearing	1	51228			
40	Inter-axle Diff. Assy w/o Lube Pump		104509	104509	104509	95213
	w/ Lube Pump Includes Items 41-47	NOTE 10	213608	104509	104509	
41	DIFF CASE KIT w/o Lube Pump		94810	94810	94810	91850
	w/ Lube Pump		Order #40	94810	94810	
	Case Half (NSS) w/o Lube Pump	2	102621	102621	102621	88029
	w/ Lube Pump		127784	102621	102621	
42	Bolt	8	85438	85438	85438	85438
43	NUT	8	57637	57637	57637	57637
	DIFF SIDE PINION & SPIDER KIT (Includes Items 44-47)	1				
	w/o Lube Pump		96381	96381	96381	96380
	w/ Lube Pump			96381	96381	
44	Side Pinion w/o Lube Pump	4	95214	95214	95214	95210
	w/ Lube Pump		95214	95414	95214	
45	Side Pinion Bushing w/o Lube Pump	4	95215*	95215*	95215*	95211*
	w/ Lube Pump			95215*	95215*	
46	Side Pinion Thrust W/isher w/o Lube Pump	4	85437*	85437*	85437*	25968*
	w/ Lube Pump		127785	85437*	85437*	
47	Spider w/o Lube Pump		95216	95216	95216	95212
	w/ Lube Pump		127783	95216	95216	
48	Helical Side Gear & Bushing Assy Includes Item 49	1	128042	128042	85432 NOTE 5	45476
	Side Gear (NSS)		128018	128018	85431	45474
49	Helical Side Gear Bushing	2	85991*	85991*	85991*	48921*
50	Helical Side Gear Snap Ring	1	85997*	85997*	85997*	46983*

Forward Tandem Axle Differential Carrier

Item No.	Part Name	Qty Per Axle	DS341, DS402(P), DS451-P Built After 4-6-89	DS381(P), DS402(P), DS401-P, DS451-P, Built Before 4-6-89	DS340, DS380(P), DS400-P NOTE 1	34DS 38DS
51	Helical Side Gear Thrust Washer	1	85429*	85429*	85429*	45477 *
52	Helical Side Gear "D" Washer	1	45478*	45478*	45478*	45478*
53	Lockout Sliding Clutch	1	128016	128016	128016	128016
54	INPUT SHAFT, WASHER & NUT KIT Includes Item 52 & 63				NOTE 6	NOTE 7
	Models w/o Lube Pump	1	115122	115122	103289	98693
	Shaft (NSS) 44 splines, 2.250" dia.		110823	110823		
	Shaft (NSS) 16 splines, 2.125" dia.				103283	
	Shaft (NSS) 10 splines, 1.969" dia.					88285
	Models w/ Lube Pump	1	115126	115126	106709	
	Shaft (NSS) 44 splines, 2.250" dia.		110805	110805		
	Shaft (NSS) 16 splines, 2.125" dia.				102608	
55	Input Shaft Bearing Cone	1	91136*•	91136*•	85425*	83469*
56	Input Bearing Cover, Cup & Seal Assy Includes Items 57 & 61					NOTE 7
	Models w/o Lube Pump	1	211634	110826	85423	86813
	Cover (NSS)		110824	110824	85421	86811
	Models w/ Lube Pump	1	211888	110808	102629	
	Cover (NSS)		110807	110807	102614	
57	Input Bearing Cup	1	98388*•	98388*•	85424*•	83462*•
58	Input Bearing Cover Shim	AR				
	.003"		45498*	45498*	45498*	45498*
	.005"		70709*	70709*	70709*	70709*
	.010"		45499*	45499*	45499*	45499*
	.020"		85406*	85406*	85406*	85406*
59	Bearing Cover Cap Screw	5	113324	113324	113324	113324
60	Lockwasher	5	90414	90414		
	OIL SEAL & SHIM KIT Includes Items 27,58,61,83 & RTV NOTE 9	1	114465	114465	114465	114465
61	Oil Seal	NOTE 9	1	127719*•	127719*•	127720*•
	Input Bearing Spacer Not illustrated	1			85427	
62	Input Yoke			SEE INFORMATION AND CHART ON page 25.		
63	Input Shaft Nut	1	95207	95207	95207	95206
64	Flat Washer	1	85404*	85404*	85404*	56864*
65	Diff. Carrier Cover Assy					
	Models w/o Lube Pump	1	45481	45481	45481	45481
	Models w/ Lube Pump	1	102627	102627	102627	
	Includes Items 66-67					
	Cover (NSS)		102606	102606	102606	
66	Pipe Plug 1"	1	90325	90325	90325	
	Models w/ Lube Pump					
67	Expansion Plug Models w/ Lube Pump	1	9797	9797	9797	

Forward Tandem Axle Differential Carrier

Item No.	Part Name	Qty Per Axle	DS341, DS402(P), DS451-P Built After 4-6-89	DS381(P), DS402(P), DS401-P, DS451-P, Built Before 4-6-89	DS340, DS380(P), DS400-P NOTE 1	34DS 38DS
68	Carrier Cover Cap Screw					
	Models w/o Lube Pump (long)	5	12063	12063	12063	12063
	(short)	4	90069	90069	90069	90069
	Models w /Lube Pump (long)	4	12063	12063	12063	
	(short)	4	90069	90069	90069	
	(12 pt)	1	81855	81855	102605	
69	Lockwasher	9	90417	90417	90417	90417
70	Magnetic Filler Screen Models w/ Lube Pump	1	102611	102611	102611	
71	LUBE PUMP REPLACEMENT KIT Models w/ Lube Pump Includes Items 72-77	1	106368	106368	106368	
72	Pump Drive Gear	1	111448	111448	102609	
73	Drive Gear Locknut	1	111451	111451	63028	
	Drive Gear Woodruff Key Not Illustrated	1			81471	
74	Cover "O" Ring	1	102620*	102620*	102620*	
75	Cover Dowel Pin	2	102617	102617	102617	
76	Cover Cap Screw	4	102618	102618	102618	
77	Lockwasher	4	90419	90419	90419	
78	Pinion Pilot Bearing	1	127051*•	15828*•	15828*•	15828*•
79	Pinion Bearing Cone (Inner)	1	85439*•	85439*•	85439*•	45460*•
	Pinion Bearing Cone (Outer)	1	110846*•	110846*•	45460*•	45460*•
80	Pinion Bearing Spacer	AR		See chart on page 26		
81	Pinion Bearing Cage & Cup Assy Includes Item 82	1				
	Ratios 3.55 & 3.70		110731	110731	107322	107322
	Cage (NSS)		110730	110730	107321	107321
	Ratios 3.08, 3.25, 3.36, 3.90-7.17		110733	110733	107324	107324
	Cage (NSS)		110732	110732	107323	107323
82	Pinion Bearing Cup (Inner)	1	14217*•	14217*•	14217*•	14217*•
	Pinion Bearing Cup (Outer)	1	35502*•	35502*•	14217*•	14217*•
83	Pinion Bearing Cage Shim	AR				
	.003"		45461*	45461*	45461*	45461*
	.005"		62829*	62829*	62829*	62829*
	.010"		45462*	45462*	45462*	45462*
	.020"		62830*	62830*	61830*	62830*
	.030"		45463*	45463*	45463*	45463*
84	Bearing Cage Cap Screw	6	62158	62158	62158	62158
85	Lockwasher	6	37207	37207	37207	37207
86	Pinion Helical Gear	1	110845	110845		
	Ratios 3.70				46977	
	Other Ratios				74991	
	34/38DSB,C					46977
	34/38DSD,E					74991
87	Slotted Pinion Nut	1	118806	118806		

Item No.	Part Name	Qty Per Axle	DS341, DS402(P), DS451-P Built After 4-6-89	DS381(P), DS402(P), DS401-P, DS451-P, Built Before 4-6-89	DS340, DS380(P), DS400-P NOTE 1	34DS 38DS
88	Roll Pin	1	118807	118807		
	Slotted Nut	1		NOTE 8	95206	95206
89	Air-Operated Lockout Assy					
	Models w/ Lube Pump	1		SEE page 16 AND page 17		
	Models w/o Lube Pump	1		SEE page 16 AND page 17		
90	Shift Fork & Push Rod Assy					
	Models w/ Lube Pump	1	102613	102613	102613	
	Models w/o Lube Pump	1	45859	45859	45859	45859
	Gasket Compound	AR	107276*	107276*	107276*	107276*

NSS - Not Sold Separately

NOTE 1: Early models axles are equipped with 2-Speed differential carrier produced prior to May 1, 1978 (date code 1218). A parts listing for these models can be found on page 11.

NOTE 2: 120924 is supplies with 11081/110812 Output Shaft Bearing Cup & Cones as well as 110810 Output Shaft Side Gear. Power Divider must also be converted to DS341/381/401. 120923 is supplies with 110811/110812 Output Shaft Bearing Cup & Cones as well as 119896 Output Shaft Side Gear. Power Divider must also be converted to DS340/380/400 or DS341/381/401.

NOTE 3: 98603 is interchangeable with 115123 by also using a new Input Yoke.

NOTE 4: For earlier style output Shafts 46647 and 98603, use 44178 snap ring.

NOTE 5: Helical Gear Conversion Kit 113561.

NOTE 6: 103289 and 106709 interchangeable with 115122 by also using 211634 Cover, Cup & Seal Assy, 91136 Bearing Cone and new Input Yoke.

NOTE 7: Early model axles use a ball bearing on input shaft. To convert ball bearing to taper bearing, use Kit 86967 which contains items 53, 54 & 56.

NOTE 8: Axles built prior to May 1, 1982 use 95207 self-locking nut. Later models use 118806 slotted nut plus 118807 roll pin.

NOTE 9: **PLEASE REVIEW INFORMATIN ON TOP OF page 25 BEFORE ORDERING OIL SEALS.**

NOTE 10: 213608 replaces P/N 104509 in models with lube pump only. Sold only as complete assembly.

DS340 & DS380 Models w/2-Speed Differential Carriers

From 1972 until May 1, 1978 (date code 1218) DS340 and DS380 (forward and rear) tandems were built with 2-Speed differential carriers. The listing below shows part number variation between tandems built with single-speed and 2-Speed differential carriers. Those parts identified with an * are the same as D340/D380 dual range tandems.

Carrier design variations are shown in the adjacent illustrations.

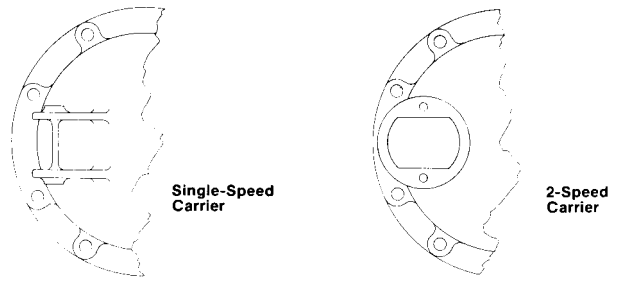

Part Name (Qty. per Axle)	Forward Axle		Rear Axle	
	Single-Speed Carrier	2-Speed Carrier	Single-Speed Carrier	2-Speed Carrier
Differential Carrier & Bearing Caps				
Diff. Carrier & Bearing Cap Assy. (1)	120924	120926	67804	67759*
Bearing Cap Screw (4)	127179	32732*	127179	32732*
Flat Washer (4)	26772	32912*	26772	32912*
Bearing Adjuster Lock (1) (Forward RH; Rear LH)	14275	45448	14275	45448
Lockwire (2)		12563*		
Adjuster Lock Cap Screw (2)		12562		12562
Oil Trough (1)		67857		82440
Oil Trough Screw (Forward 1; Rear 2)		67815		67815
Upper Expansion Plug (1)		30703*		30703*
Lower Expansion Plug (1)		9797*		9797*
Shift Unit Opening Cover (1)		45521*		45521*
Cap Screw (2)		20807*		20807*
Lockwasher (2)		90415*		90415*
Ring Gear & Wheel Differential (Forward RH; Rear LH)				
Diff. Bearing Adjuster (1)	31562	111022	31562	111022
Diff. Bearing Cup (1)	90943	27816*	90943	27816*
Diff. Bearing Cone (1)	6082	27817*	6082	27817*
Wheel Diff. Case Kit 3.70-5.29	106397	106974	106397	106974
5.57-7.17	94799	106975	94799	106975
Drive Pinion & Pinion Bearing Cage				
Lockwasher (6)			37207	37207
Basic Overhaul Kit	110593	110578	110555	110579

Rear Tandem Axle Differential Carrier

Single Reduction

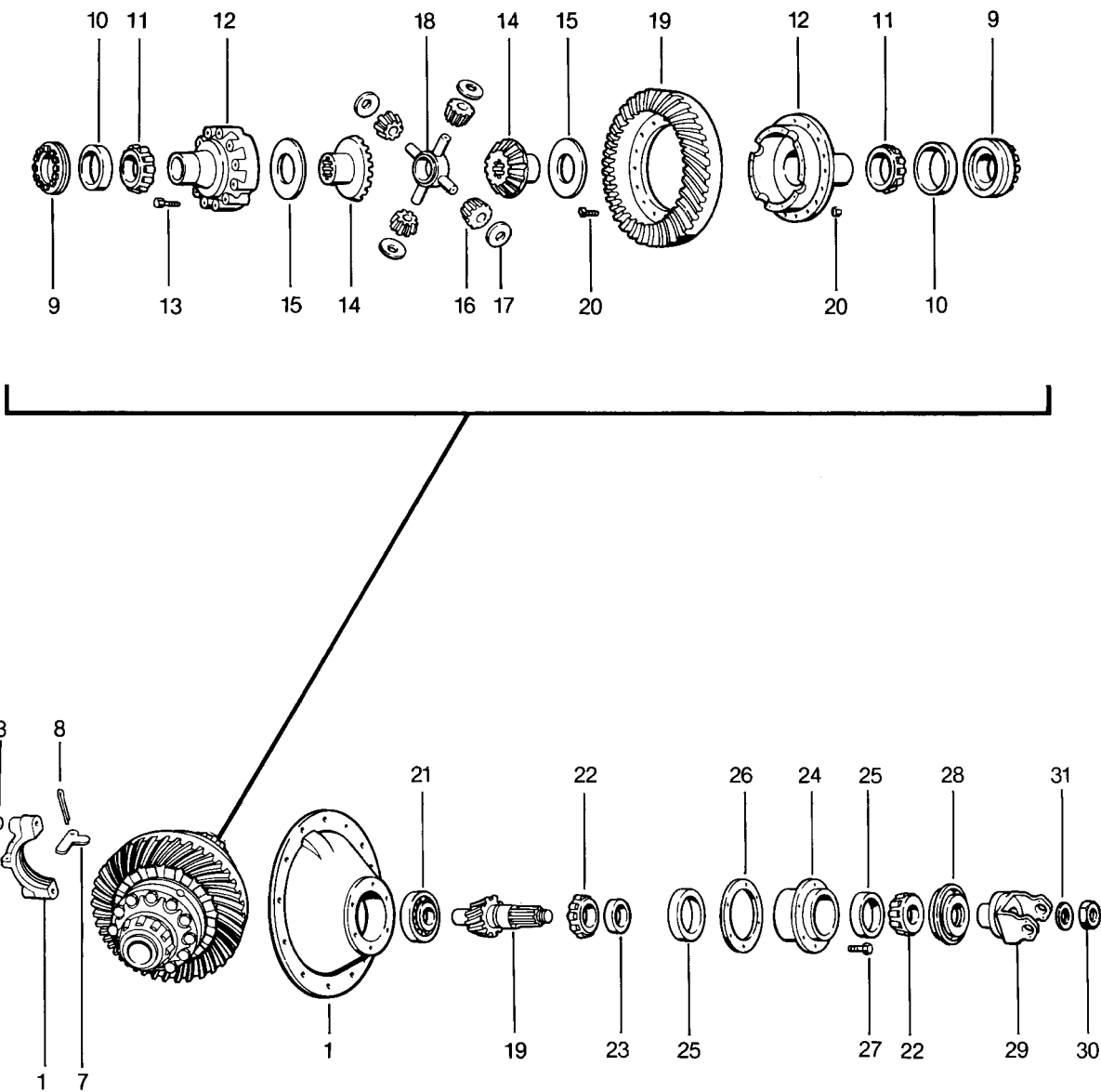

Rear Tandem Axle Differential Carrier

Item No.	Part Name	Qty Per Axle	RS341,RS402, RS451 Built After 4-6-89	RS341, RS381,RS401, RS402, RS451 Built Before 4-6-89	RS340, RS380, RS400	34RS 38RS
	BASIC OVERHAUL KIT (Contents identified with *)	1	211218*	110555*	110555*	110555*
	BEARING KIT (Contents identified with •)	1	211223•	99041•	99041•	99041•
	Diff. Carrier & Bearing Caps	1	211219	67804	67804	67804
	Carrier Casting No.(NSS) Includes Items 1-4		128109	106402	106402	106402
2	Bearing Cap Screw	4	127179	127179	127179	127179
3	Flat Washer	4	26772	26772	26772	26772
4	Lockwire	4			90538	90538
5	Bearing Cap Adjuster Lock (RH)	1	13377	13377	13377	13377
6	Cotter Pin (RH)	1	90873	90873	90873	90873
7	Bearing Cap Adjuster Lock (LH)	1	14275	14275	14275	14275
8	Cotter Pin (LH)	1	90876	90876	90876	90876
9	Diff. Bearing Adjuster (RH)	1	110243	110243	27842	27842
	Diff. Bearing Adjuster (LH)	1	31562	31562	31562	31562
10	Diff. Bearing Cup (RH)	1	9803*•	9803*•	9803*•	9803*•
	Diff. Bearing Cup (LH)	1	90943*•	90943*•	90943*•	90943*•
11	Diff. Bearing Cone (RH)	1	27813*•	27813*•	27813*•	27813*•
	Diff. Bearing Cone (LH)	1	6082*•	6082*•	6082*•	6082*•
	WHEEL DIFF. CASE KIT					
	Ratios 3.08 & 3.25	1	212202			
	Ratios 3.36-5.29	1	106397	106397	106397	
	Ratios 5.57-7.17 Includes Items 12-13 & 110243 adjuster	1	124374	124374	124374	
	12" O.D. -1/2" bolt Flanged Half 91114	"1				96794
	11-1/2" O.D. -1/2" bolt Flanged Half 91116	1				96795
	5/8" bolt Flanged Half 88677	1				124374
12	Diff. Case (Plain Half) (NSS)	1	210017	210017	210017	210017
	Diff. Case (Flanged Half) (NSS)	1				
	Ratios 3.08 & 3.25		127823			
	Ratios 3.36-5.29		103865	103865	103865	
	Ratios 5.57-7.17		88677	88677	88677	
13	Diff Case Cap Screw	12	96271	96271	96271	96271
	WHEEL DIFF. SIDE GEAR & PINION KIT Includes Items 14-18					
	Models: 34,340,341	1	114469	114469	98850	98850
	38,380,381,402	1	114470	114470	85358	85358
	400,401,451	1	98853	98853	98853	
	WHEEL DIFF. KIT LESS SIDE GEARS Includes Items 15-18	1	118748	118748	118748	118748

NSS - Not Sold Separately

NOTE 1: PLEASE REVIEW INFORMATIN ON TOP OF PAGE 25 BEFORE ORDERING OIL SEALS.

Rear Tandem Axle Differential Carrier

Item No.	Part Name	Qty Per Axle	RS341,RS402,RS451 Built After 4-6-89	RS341, RS381,RS401,RS402, RS451 Built Before 4-6-89	RS340,RS380,RS400	34RS 38RS
14	Side Gear	2				
	Models: 34,340,341		110525	110525	37072	37072
	38,380,381,402		110527	110527	37069	37069
	400,401,451		85486	85486	85486	
15	Side Gear Thrust Washer (RH)	2	27827	27827	27827	27827
16	Side Pinion 104139 replaces 37071	4	104139	104139	104139	104139
17	Side Pinion Thrust Washer	4	27810*	27810*	27810*	27810*
18	Spider	1	38289	38289	38289	38289
19	RING GEAR & DRIVE PINION SET Includes Item 20	1	Matched Parts; see separate listing on page 21			
20	RING GEAR NUT & BOLT KIT (5/8")	1	70745	70745	70745	70745
	Bolt	16	67586	67586	67586	67586
	Nut	16	60600	60600	60600	60600
	RING GEAR NUT & BOLT KIT (1/2")	1				69957
	Bolt	16				69117
	Nut	16				67592
21	Pinion Pilot Bearing	1	127051*•	15828*•	15828*•	15828*•
22	Pinion Bearing Cone (Inner)	1	45460*•	12496*•	12496*•	12496*•
	Pinion Bearing Cone (Outer)	1	12496*•	12496*•	12496*•	12496*•
23	Pinion Bearing Spacer	AR	See chart on page 26			
24	Pinion Bearing Cage & Cup Assy Includes Item 25					
	Ratios 3.55 & 3.70	1	127039	75108	75108	
	Cage (NSS)		127038	75107	75107	
	Ratios 3.08, 3.25, 3.36, 3.90-7.17	1	107496	75110	75110	
	Cage (NSS)		107495	75109	75109	
	34/38RSB,C	1				75108
	34/38RRD,E					75110
25	Pinion Bearing Cup (Inner)	1	14217*•	12495*•	12495*•	12495*•
	Pinion Bearing Cup (Outer)	1	12495*•	12495*•	12495*•	12495*•
	OIL SEAL & SHIM KIT Includes Items 26,28 & RTV	1	213763	213764	213764	213764
			NOTE 1			
26	Pinion Bearing Cage Shim	AR				
	.003"		107567*	43588*	43588*	43588*
	.005"		107568*	107568*	107568*	107568*
	.010"		107569*	43589*	43589*	43589*
	.020"		107570*	107570*	107570*	107570*
	.030"			43590*	43590*	43590*
27	Bearing Cage Cap Screw	6	113325	113325	113325	113325
28	Oil Seal	1	127721*•	127721*•	127721*•	127721*•
29	Input Yoke	1	SEE INFORMATION AND CHART ON PAGE 25.			

NSS - Not Sold Separately

NOTE 1: PLEASE REVIEW INFORMATION ON TOP OF PAGE 25 BEFORE ORDERING OIL SEALS.

Rear Tandem Axle Differential Carrier

Item No.	Part Name	Qty Per Axle	RS341,RS402, RS451 Built After 4-6-89	RS341, RS381,RS401, RS402, RS451 Built Before 4-6-89	RS340, RS380, RS400	34RS 38RS
30	Pinion Nut	1	95206	95206	95206	
	Ratio 3.70-4.33 (1-31/32" spline)	1				95206
	4.33-7.17 (1-3/4" spline)	1				95205
31	Flat Washer	1	56864*	56864*•	56864*•	4327*•
	Gasket Compound	AR	107276*•	107276*•	107276*•	107276*•

NSS - Not Sold Separately

NOTE 1: PLEASE REVIEW INFORMATIN ON TOP OF PAGE 25 BEFORE ORDERING OIL SEALS.

Differential Lockout (Forward Axle)

Current Production Model

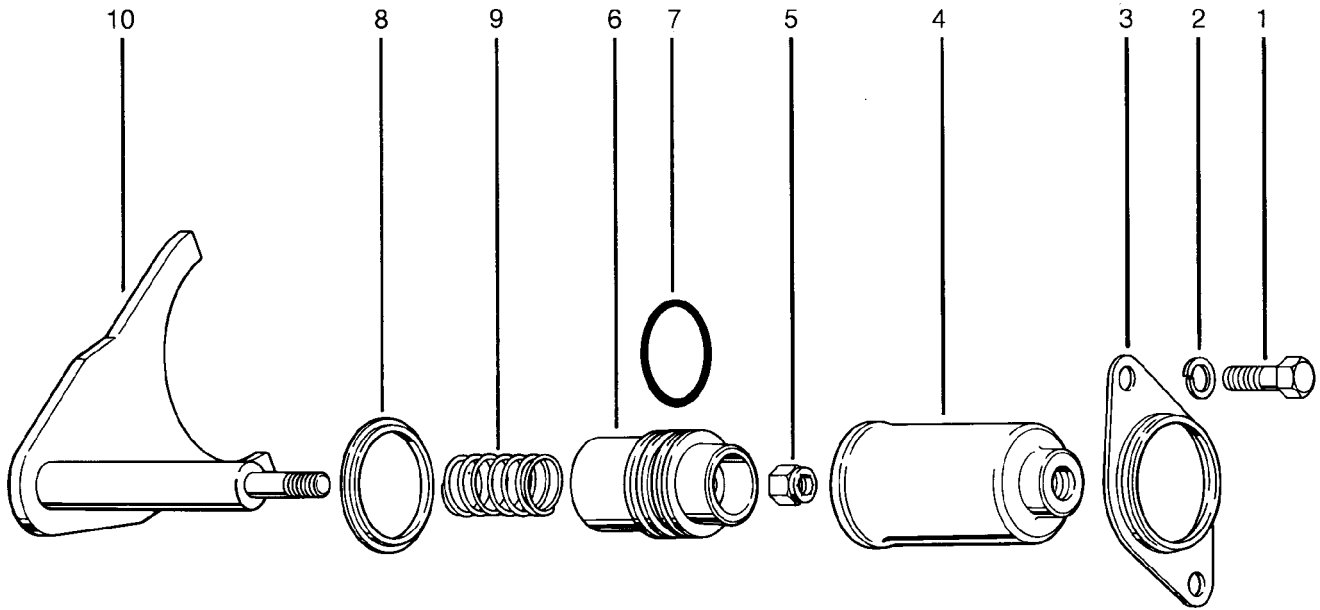

Item No.	Part Name	Axle	Spicer Part No.	Remarks
	Air-Operated Lockout Assy.	1	123216	w/ lube pump
	Includes Items 1-10	1	123217	w/o lube pump
	REPAIR KIT	1	211197	w/lube pump
	Includes Items 5-9		211198	w/o lube pump
1	Cap Screw	2	210381	
2	Lockwasher	2	90415	
	PISTON KIT	1	121332	w/ lube pump
	Includes Items 3-8	1	121333	w/o lube pump
3	Mounting Bracket	1	127675	
4	Piston Housing	1	119923	
5	Locknut	1	128160	
6	Piston	1	119913	Models w/ lube pump
		1	119912	Models w/o lube pump
7	Piston "O" Ring	1	210180	
8	Shoulder Washer	1	210452	
9	Compression Spring	1	31038	
10	Shift Fork & Push Rod Assy.	1	102613	Models w/ lube pump
		1	45859	w/o lube pump

Differential Lockout (Forward Axle)

Non-Current Production Model

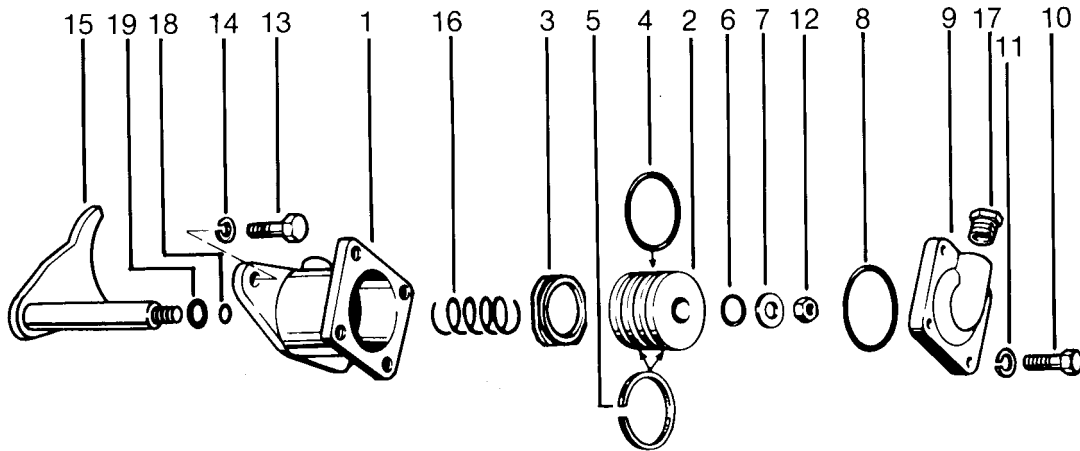

Item No.	Part Name	Qty. per Axle	Standard Part No.	Navistar Reversed-Air Part No.	Remarks
	Air-Operated Lockout Assy NSS (Note 1)	1	58421	96919	Models w/o lube pump
	Includes Items 1-19 unless noted NSS (Note 1)	1	104600	107621	Models w/ lube pump
	DIFFERENTIAL AIR LOCKOUT RETROFIT KIT (Note 1)	1	211200		Models w/o lube pump
		1	211199		Models w/ lube pump
	LOCKOUT BODY KIT	1	34779		Models w/o lube pump
	Includes Items 1-9	1	104599		Models w/ lube pump
	AIR LOCKOUT SERVICE KIT	1	211201	211202	Models w/o lube pump
	Includes Items 3-8, 12, 16, 18-20				
1	Shift Cylinder Body	1	32828	96913	
2	Shift Cylinder Piston	1	32834	96915	
3	Piston Stop	1	102616		Models w/ lube pump
4	Piston Grommet	1	32832	32832	
5	Piston Felt Oiler	2	96916	96916	
6	Push-Rod Grommet	1	32826		
7	Push-Rod Flat Washer	1	111406	111406	
8	Cover Grommet	1	60817	60817	
9	Body Cover	1	32831	32831	Models w/o lube pump
	Body Cover	1	32831	32831	Models w/ lube pump
10	Cover Cap Screw	4	79363	79363	
11	Lockwasher	4	90419	90419	
12	Push-Rod Nut	1	90206	90206	
13	Body Cap Screw	2	90031	90031	
14	Lockwasher	2	90415	90415	
15	Shift Fork Assy	1	45859	96715	Models w/o lube pump
	Shift Fork Assy	1	102613	107620	Models w/lube pump

NOTE 1: Air-Operated Lockout Assembly 58421 and 104600 are no longer available. If it is necessary to repair complete unit, use Differential Air Lockout Retrofit Kits 211200 or 211199.

Differential Lockout (Forward Axle)

Item No.	Part Name	Qty. per Axle	Standard Part No.	Navistar Reversed-Air Part No.	Remarks
16	Compression Spring	1	31038	126705	
17	Cover Reducer Bushing	1		108223	Models w/ lube pump
18	Push-Rod to Piston Seal Ring	1		96912	
19	Push-Rod to Body "O"Ring	1		96911	
20	Gasket Compound	AR	107276	107276	

NOTE 1: Air-Operated Lockout Assembly 58421 and 104600 are no longer available. If it is necessary to repair complete unit, use Differential Air Lockout Retrofit Kits 211200 or 211199.

Axle Housing & Axle Shafts

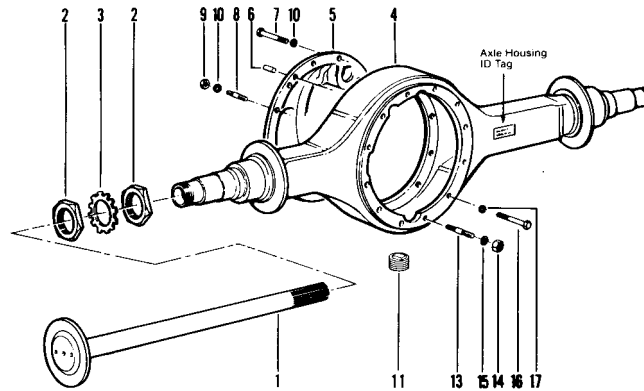

Item No.	Part Name	Axle	Spicer Part No.	Remarks
	Axle Shaft	2		Length Flange Holes OEMs*
	34D, D340		56980	40-29/32" 12 (.783") taper holes
	16 splines, 1.980 O.D.		62165	41-5/16" 12 (.750") taper holes
	D341		110882	40-29/32" 12 (.783") taper holes 1
	39 splines, 2.000" O.D.		110886	41-5/16" 12 (.745") taper holes 3
	38D, D380 (P)		56981	40-1/8" 8 (.760") thru holes
	16 splines, 2.125" O.D.		80929	40-5/8" 6 (.843") taper holes
			62166	41-5/16" 8 (.948") taper holes
			76917	41-5/16" 6 (.635") thru holes
			81216	41-19/32" 8 (.948") taper holes
	D381 (P), D402 (P)		110887	40-1/8" 8 (.760") thru holes
	41 splines, 2.100" O.D.		126877	40-5/8" 8 (.948") taper holes 1
			110883	41-5/16" 8 (.640") taper holes 3,7
			110888	41-5/16" 6 (.635") thru holes 2,5,6
			110884	41-19/32" 8 (.948") taper holes 1
			127008	44-3/8" 8 (.635") thru hole 5,6
	D400-P, D401-P		88192	41-3/8" 8 (.640") taper holes 1
	33 splines, 2.125" O.D.		91133	41-3/8" 8 (.635") thru holes 6
			94224	40-13/32" 8 (.750") thru holes
			99407	41-7/32" 8 (.635") thru holes 2,5,6
2	Hub Bearing Adjuster Nut (see Note 1) (Forward and Rear Axles) (varies by OEM)	4	19186**	(0.47" thick) D341, 34D
			78944	(3/8" thick) D381, 381-P, 402, 402-P, 38D
			95372	(0.562" thick) D381, 381-P, 402, 402-P, 38D
			11249**	(17/32" thick) all except D341
		2	119881	(outer) all except D341
		2	119882	(inner) all except D341
3	Bearing Adjuster Lockwasher (see Note 1) (Forward and Rear Axles) (*varies by OEM)	2	30714	
			11245	
			119883	all except D341
4	Axle Housing Assy (forward & rear)	1		See OEM Catalog

*OEMs - 1-Ford, 2-Freightliner, 3-GMC, 4-Navistar, 5-Kenworth, 6-Peterbilt, 7-White.

**Hub Bearing Adjuster Nut Wrench is available, nut 19186, use wrench 15751; nut 11249, use wrench 24042.

Note 1: Wheel Nut & Lock Kit #121343 contains 2 each 119881 outer nut, 119882 inner nut, 119883 nut lock and instruction sheet. This kit is recommended when servicing all D381 thru D451 axles. However, the individual parts are not interchangeable with existing parts.

Ring Gear and Pinion Identification

Ring Gear and Drive Pinion are matched parts and must be replaced in sets.

Complete identification is stamped on both parts shown in the adjacent drawing.

Order by J&S "Set No." which includes drive pinion nut.

Typical Gear Sets

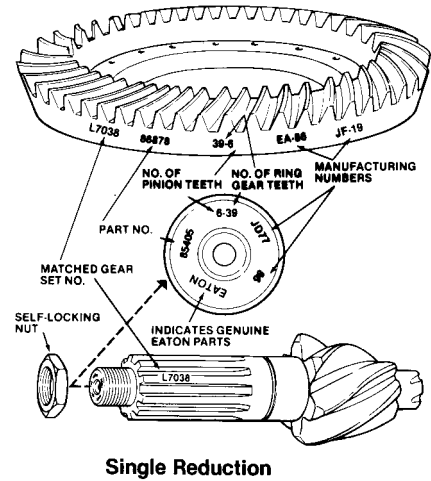

Drive Pinion and Ring Gear Set

Forward Axles

DS341, 402, 402-P, 451-P

Units Built After 4-6-89

Pinion Spline; 41, 2.100" dia.

Single Reduction

Ratios	Gear Set	Gear (NSS)	Pinion (NSS)
3.08*	212901	128023 (37T)	128024 (12T)
3.25*	212145	127884 (39T)	127885 (12T)
3.36*	127265	120042 (37T)	127065 (11T)
3.55*	127266	109867 (39T)	127066 (11T)
3.70*	127267	88000 (37T)	127067 (10T)
3.90	127268	99742 (39T)	127068 (10T)
4.11	127269	86356 (37T)	127069 (9T)
4.33	127270	86358 (39T)	127070 (9T)
4.56	127271	86360 (41T)	127071 (9T)
4.88	127272	86362 (39T)	127072 (8T)
5.29	127273	86364 (37T)	127073 (7T)
5.57	127274	86366 (39T)	127074 (7T)
6.14	127275	86877 (43T)	127075 (7T)
6.50	127276	86878 (39T)	127076 (6T)
7.17	127277	86879 (43T)	127077 (6T)

*16" gearing

DS341, 381, 381-P, 401-P, 402, 402-P, 451-P

Units Built Before 4-6-89

Pinion Spline; 41, 2.100" dia.

Single Reduction

Ratios	Gear Set	Gear (NSS)	Pinion (NSS)
3.36*	120761	120042 (37T)	120041 (11T)
3.55*	111174	109867 (39T)	111139 (11T)
3.70*	111175	88000 (37T)	111140 (10T)
3.90	111176	99742 (39T)	111141 (10T)
4.11	111177	86356 (37T)	111142 (9T)
4.33	111178	86358 (39T)	111143 (9T)
4.56	111179	86360 (41T)	111144 (9T)
4.88	111180	86362 (39T)	111145 (8T)
5.29	111181	86364 (37T)	111146 (7T)
5.57	111182	86366 (39T)	111147 (7T)
6.14	111183	86877 (43T)	111148 (7T)
6.50	111184	86878 (39T)	111149 (6T)
7.17	111185	86879 (43T)	111150 (6T)

*16" gearing

Item No.	Part Name	Axle	Spicer Part No.	Remarks
5	Axle Housing Cover (forward axle only)	1		
6	Axle Housing Cover Locating Dowel	2	7641	
7	Axle Housing Cover Cap Screw	1	119784	
8	Axle Housing Cover Stud	11	47500	
9	Nut	11	42364	
10	Lockwasher	11	90415	
11	Magnetic Drain Plug		54254	
12	Magnetic Filler Plug (rear axle) (not illustrated)		54254 3/4" 75130 1"	
DIFF. CARRIER ATTACHING PARTS				
FORWARD AXLE				
13	Stud	10	36435	
14	Nut	10	90208	
15	Lockwasher	10	90422	
16	Cap Screw	2	38589	
17	Lockwasher	2	90422	
REAR AXLE				
13	Stud	12	36435	
14	Nut	12	90208	
15	Lockwasher	12	90422	

*OEMs - 1-Ford, 2-Freightliner, 3-GMC, 4-Navistar, 5-Kenworth, 6-Peterbilt, 7-White.

**Hub Bearing Adjuster Nut Wrench is available, nut 19186, use wrench 15751; nut 11249, use wrench 24042.

Note 1: Wheel Nut & Lock Kit #121343 contains 2 each 119881 outer nut, 119882 inner nut, 119883 nut lock and instruction sheet. This kit is recommended when servicing all D381 thru D451 axles. However, the individual parts are not interchangeable with existing parts.

Axle Housings (forward and rear)

All drive axles are mounted in Spicer® fabricated steel axle housings. These housings are developed to meet specific OEM requirements for dimensions, suspension mounting and brakes. If housing replacement is necessary, provide the truck dealer with the following information:

- a. Year, make and model of the truck.
- b. Axle model and ground loading capacity.
- c. Axle specification number.
- d. Type of brakes used.

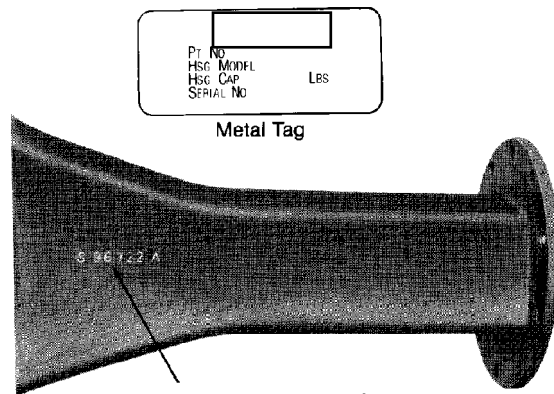

Note: Facing rear of truck, axle specification number will be on right side.

Axle Shafts (forward and rear)

These axles will be found with a number of different axle shafts, on the basis of OEM specification. When ordering replacement axle shafts, note the part number stamped into the flange.

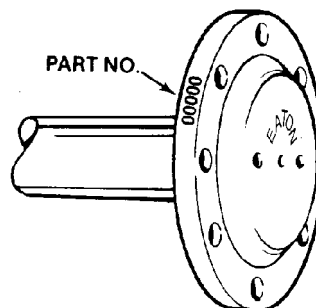

Drive Pinion and Ring Gear Set

Rear Axles

RS341, 402, 451

Pinion Spline; 39, 2.000" dia.

Single Reduction

Ratios	Gear Set	Gear (NSS)	Pinion (NSS)
3.08*	212902	128025 (37T)	128026 (12T)
3.25*	212146	127886 (39T)	127887 (12T)
3.36*	127252	120045 (37T)	127052 (11T)
3.55*	127253	109862 (39T)	127053 (11T)
3.70*	127254	88013 (37T)	127054 (10T)
3.90	127255	99746 (39T)	127055 (10T)
4.11	127256	86372 (37T)	127056 (9T)
4.33	127257	86374 (39T)	127057 (9T)
4.56	127258	86376 (41T)	127058 (9T)
4.88	127259	86378 (39T)	127059 (8T)
5.29	127260	86380 (37T)	127060 (7T)
5.57	127261	86880 (39T)	127061 (7T)
6.14	127262	86881 (43T)	127062 (7T)
6.50	127263	86882 (39T)	127063 (6T)
7.17	127264	119237 (43T)	127064 (6T)

*16" gearing

RS341, 381, 401, 402, 451

Pinion Spline; 39, 2.000" dia.

Single Reduction

Ratios	Gear Set	Gear (NSS)	Pinion (NSS)
3.36*	120763	120045 (37T)	120044 (11T)
3.55*	111501	109862 (39T)	111466 (11T)
3.70*	111502	88013 (37T)	111467 (10T)
3.90	111503	99746 (39T)	111468 (10T)
4.11	111504	86372 (37T)	111469 (9T)
4.33	111505	86374 (39T)	111470 (9T)
4.56	111506	86376 (41T)	111471 (9T)
4.88	111507	86378 (39T)	111472 (8T)
5.29	111508	86380 (37T)	111473 (7T)
5.57	111509	86880 (39T)	111474 (7T)
6.14	111510	86881 (43T)	111475 (7T)
6.50	111511	86882 (39T)	111476 (6T)
7.17	111512	86883 (43T)	111477 (6T)

*16" gearing

Gear Sets

The charts on these pages indicate how many axle models can be serviced using the new high-torque gear sets when slight modifications are made. In all cases, the "replace with" column is upgraded gear sets.

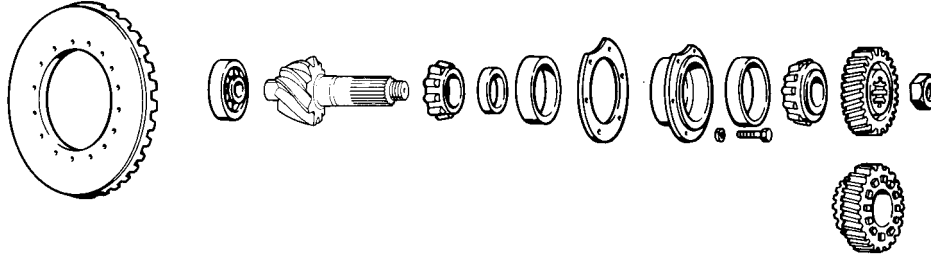

Forward Axle Models: DS340, DS380, DS380-P, DS400-P (Single Reduction)

Ratio	Current Part No.	Replace with	Pinion Splines: 41, 2.100" dia.
3.55	110862	111174	Plus Items listed below and 110731 cage & cup
3.70	95557	111175	
3.90	99745	111176	
4.11	95558	111177	
4.33	95559	111178	Plus items listed below and 110733 cage & cup
4.56	95560	111179	
4.88	95561	111180	
5.29	95562	111181	
5.57	95563	111182	
6.14	95564	111183	
6.50	95565	111184	
7.17	95566	111185	

Plus 110844 Helical & Bushing, 110845 Pinion Helical, 110736 thru 110803 Pinion Bearing Spacer (as req'd), 110846 Outer Pinion Bearing Cone (118806 slotted nut and 118807 roll pin are included w/gear set).

Note: These changes can be applied to 34DS and 38DS, if power divider conversion is also used.

When changing ratios:

3.55-5.29 to 5.57-7.17 use Case Kit 94799 & 110733 Cage & Cup Assembly.

5.57-7.17 to 3.55-5.29 use Case Kit 106397 & 110731 Cage & Cup Assembly.

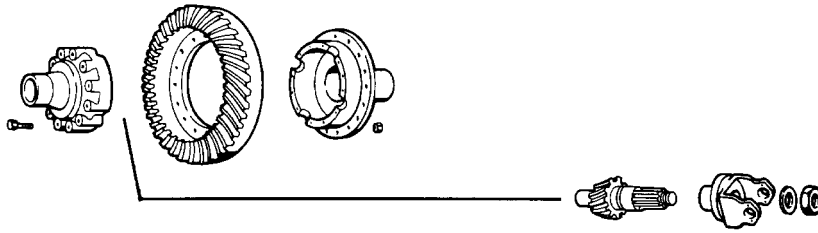

**Rear Tandem Axles: 34RS, 38RS, RS340, RS380, RS400 (Single Reduction)
Single Drive Axles: 17100-1,17120-1,18100-1,18120-1 (Single Reduction)**

Bolt Hole	1/2"	1/2"	5/8"	5/8"	
Gear Dia.	16"	16-1/2"	16"	16-1/2"	RS340,
Models	17-18100-1 34/38RSB,C	17-18120-1 34/38RSD,E	17-18100-1 34/38RSB,C	17-18120-1 34/38RSD,E	380, 400

Ratio:	Current Part Numbers				Replace with	Pinion Splines: 9, 2.000" dia.	
3.55				110864	111501	17, 18, 34, 38 Series Only	
3.70	96619		96619	96641	111502	Plus 106397 Case Kit & New Input Yoke	
3.90				99749	111503		
4.11	96620		96620	96642	111504		
4.33	96621/99930		96621/99930	96643	111505	340, 380, 400 Series Only	
4.56	96622		96622	96644	111506	Plus new Input Yoke	
4.88	96623		96623	96645	111507	17, 18, 34, 38 Series Only	
5.29	96624		96624	96646	111508	(w/ 1/2" bolt holes)	
5.57	96625	96626	96625	96626	96647	111509	Plus 94799 Case Kit & New Input Yoke & 120780 Nut & Bolt Conversion Kit
6.14		96627		96627	96648	111510	
6.50		96628		96628	96649	111511	340, 380, 400 Series Only
7.17		96629		96629	96650	111512	Plus New Input Yoke

When changing ratios:
3.55-3.70 to 3.90-7.17 use 75110 Cage & Cup Assembly
3.90-7.17 to 3.55-3.70 use 75108 Cage & Cup Assembly

Input and Output Yokes

During the 4th Quarter of 1990, J&E began using new seals and yoke & slingers on the models in this publication. The new seals and slingers are noticeably different from the current seals and will affect interchangeability.

- The upgraded seals can be used on axles originally equipped with the old seals.
- J&E recommends the replacement of old yoke & slinger assemblies when the new seals are installed; however, the old yokes and slingers will work with the new seals.
- New yoke and slinger assemblies cannot be used with the old seal design on the forward tandem axles.
- New yoke and slinger assemblies can be used with the old seal on the tandem rear pinions.
- Yoke Assembly & Oil Seal Kits contain oil seal, yoke & slinger and instructions.
- Most non-J&E aftermarket seals will not be compatible with the new J&E yoke and slinger assemblies.
- J&E recommends the use of special installation tools conveniently packaged in the single kit (listed below).

Oil Seal Driver Installation Kit 212139 Includes:

- Instruction Sheet
- 126917 Driver Seal (Forward Input & Rear Pinion)
- 127787 Driver Seal Adapter (Forward Input)
- 127786 Driver Seal (Forward Output)

Forward Axle Models

New Input (Yoke & Mudslinger Assy.) 44 Involute - 2.25" Spline

Yoke Series	Joint Angle	Style	Yoke & Slinger	Oil Seal	Yoke Assy. & Oil Seal Kit
1610	(22°)	B	127750	127719	213172
1710	(27.5°)	C	127754	127719	213169
1710	(27.5°)	B	127752	127719	213174
1760	(30°)	C	127755	127719	213170
1760	(30°)	B	127751	127719	213173
1810	(30°)	C	127753	127719	213169
1810	(30°)	B	127749	127719	213171

New Output Yoke (Yoke & Mudslinger Assy.) 34 Involute - 1.75" Spline

Yoke Series	Joint Angle	Style	Yoke & Slinger	Oil Seal	Yoke Assy. & Oil Seal Kit
1610	(29.5°)	C	127741	127720	213178
1610	(45°)	C	127738	127720	213175
1710	(45°)	C	127740	127720	213177
1710	(33.5°)	C	127739	127720	213176

Rear Axle Models

New Pinion Yoke New Input (Yoke & Mudslinger Assy.) 39 Involute - 1.95" Spline

Yoke Series	Joint Angle	Style	Yoke & Slinger	Oil Seal	Yoke Assy. & Oil Seal Kit
1610	(23°)	C	127746	127721	213183
1610	(35.5°)	C	127745	127721	213182
1610	(45°)	C	127743	127721	213180
1710	(33.5°)	C	127744	127721	213181
1710	(45°)	C	127742	127721	213179

- B - Half Round (Brg. Strap - Tapped Holes)**
- C - Full Round**

For more information, see Technical Service Bulletin 90-06

Pinion Bearing Spacers

**34DS, 38DS, DS340, DS380(P), DS400-P, 34RS,
38RS, RS340, RS380, RS400, RS341, RS381,
RS401, RS402**

.623"-91552	.634"-91564	.645"-91602
.624"-91553	.635"-91566	.646"-91604
.625"-91554	.636"-91568	.647"-91606
.626"-91555	.637"-91572	.648"-91608
.627"-91556	.638"-91576	.649"-91610
.628"-91557	.639"-91580	.650"-91611
.629"-91558	.640"-91584	.651"-91612
.630"-91559	.641"-91588	.652"-91613
.631"-91560	.642"-91592	.653"-91614
.632"-91561	.643"-91596	.654"-91615
.633"-91562	.644"-91600	

DSS341, DS381(P), DS401-P, DS402(P)

.472"-110736	.484"-110748	.496"-110784
.473"-110737	.485"-110749	.497"-110788
.474"-110738	.486"-110750	.498"-110790
.475"-110739	.487"-110752	.499"-110792
.476"-110740	.488"-110754	.500"-110794
.477"-110741	.489"-110756	.501"-110796
.478"-110742	.490"-110760	.502"-110798
.479"-110743	.491"-110764	.503"-110799
.480"-110744	.492"-110768	.504"-110800
.481"-110745	.493"-110772	.505"-110801
.482"-110746	.494"-110776	.506"-110802
.483"-110747	.495"-110780	.507"-110803

Power Divider Conversion Kit

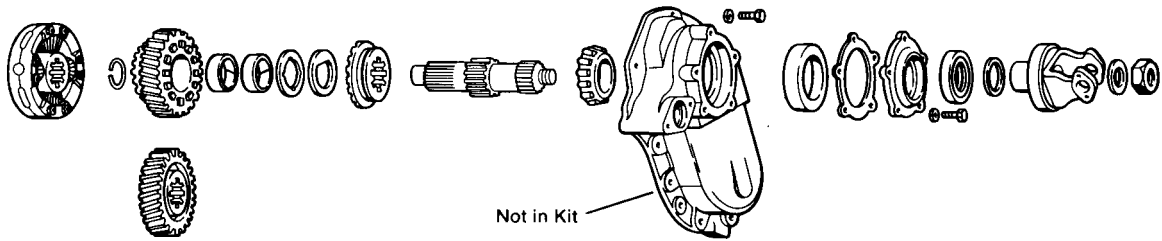

Axle Models:

34D,38D,42D,D340,D380

(all gearing - models w/o pump)

(use Swing Unit for pump conversion)

Current Part No.	Replace with	
87103	118764	Power Divider Conversion Kit
		or
45478	45478	"D" Washer, and
45498	45498	0.003" shim, and
45499	45499	0.005" shim, and
70709	70709	0.005" shim, and
85404	85404	Flat Washer, and
85406	85406	0.020" shim, and
85423	211634	Cover, Cup & Seal Assembly, and
85425	91136	Bearing Cone, and
85427	Not Used	
85429	85429	Thrust Washer
85432	128042	Helical Side Gear & Bushing, and
85436	85436	Output Shaft Side Gear, and
85994	85994	Output Shaft Snap Ring, and
85997	85997	Helical Gear Snap Ring, and
87104	See chart (available yoke tag)	
95207	95207	Nut, and
103283	110823	Input Shaft, and
104509	104509	Inter-axle Differential, and
107276	107276	RTV Sealant, and
109069	109069	Torque Tag, and
	113556	Pinion Helical Gear (10 Spline)

D380-P, D400-P to High Torque w/Lube Pump

Current Part No.	Replace with	
106709	115126	Input Shaft Kit, and
102629	211888	Cover, Cup & Seal Assembly, and
46977 or 74991	113556	Pinion Helical Gear (10 splines), and
85432	128042	Helical Side Gear & Bushing, and
85425	91136	Bearing Cone, and Input Yoke A
	115126	Input Shaft Kit, and

Available Yoke Tag

Spicer Yoke Part No.	Yoke Series
127753	1810 (30°)
127754	1710 (27.5°)
127755	1760 (30°)

PLEASE REVIEW INFORMATION ON TOP OF PAGEpage 25 BEFORE ORDERING YOKE & SLINGERS.

Helical Gear Conversion Kit #113561

This kit was designed to upgrade D340/D380 helical gears with the same product improvements that were incorporated into the high-torque tandems. The helical gears in this kit are a 5-pitch design, versus the original 7-pitch design, which makes them approximately 39 percent stronger. This improvement is particularly desirable for axles used with high-torque engines and fast ratios.

The pinion helical gear in this kit has 10 splines to accommodate all D340/D380 pinions, regardless of ratio. The helical side gear and bushing assembly is identical to the D341/D381 helical gear and is compatible with the sliding clutch, inter-axle differential, input shaft and output shaft side gears. Because the pitch is different, these gears will have to be replaced as a set, but once installed can later be serviced with individual parts.

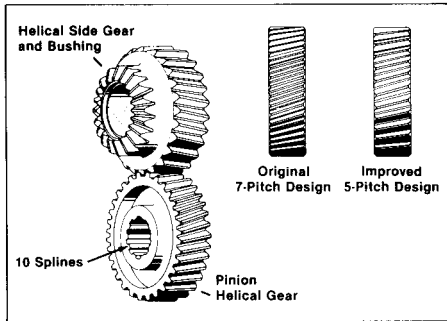

For Axle Models D340, D380, D380-P, D400-P, when using original pinion and ring gear set. All ratios. All gearing types.

If new pinion and ring gear set is used during rebuild, use instructions for helical gears in gear set section (page 23).

**Replaces
Current
Part No.**

113561 Kit includes:

128042 Helical Side Gear & Bushing	85432
113556 Pinion Helical Gear (10 splines)	46977 or 74991

Note: Kit must be used if changing either current helical gear.

Differential Carrier Assembly

These carrier assemblies are complete, less input yoke.

Side Gear Ratio	DS341	DS341-P	DS402 DS381	DS402-P DS381-P	DS451-P DS401-P	RS341	RS402 RS381	RS451 RS401
(Involute Splines)	39	39	41	41	33	39	41	33
3.08*			674686	674628			674629	
3.25*			674687	952126			674692	
3.36*	951907	951908	674456	674462	951913	951909	674468	951914
3.55*	951150	951174	674457	674463	674574	951320	674469	674575
3.70*	951151	951175	674458	674464	674474	951321	674470	674479
3.90	951152	951176	674459	674465	674475	951322	674471	674480
4.11	951153	951177	674460	674466	674476	951323	674472	674481
4.33	951154	951178	674461	674467	674477	951324	674473	674482
4.56	951155	951179	674633	674635	674478	951325	674634	674483
4.88	951156	951180	674688	674703	674566	951326	674693	674567
5.29	951157	951181	674689	674704	951205	951327	674694	951351
5.57	951158	951182	674690	951194	951206	951328	674695	951352
6.14	951159	951183	674691	951195	951207	951329	674696	951353
6.50	951160	951184	951172	951196	951208	951330	674697	951354
7.17	951161	951185	951173	951197	951209	951331	951343	951355

*16" gearing

These hybrid diff. carrier assemblies were introduced in 1985. Because of J&E's unique interchangeability, one hybrid tandem replaces several generations tandems in the same ratio and gearing type. These new carriers contain old straight spline gears (except 400 and 401 series which use the same side gears). New yokes are required to use the new carrier (see instructions on page 30).

Replaces: Side Gear Ratio	Hybrid DS341	Hybrid DS341-P	Hybrid DS 381	Hybrid DS381-P	Hybrid RS341	Hybrid RS381
(Straight Splines)	34DS DS340	DS340-P	38DS DS380	DS380-P	34RS RS340	38RS RS380
	16	16	16	16	16	16
3.36*						
3.55*	951693	951705	674551	951807	951717	674573
3.70*	951694	951706	674448	951808	951718	674451
3.90	951695	951707	674552	951809	951719	674553
4.11	951696	951708	674449	951810	951720	674452
4.33	951697	951709	674450	951811	951721	674453
4.56	951698	951710	951800	951812	951722	951824
4.88	951699	951711	951801	951813	951723	951825
5.29	674512	951712	674576	951814	674513	674577
5.57	951701	951713	951803	951815	951725	211991
6.14	951702	951714	951804	951816	951726	951828
6.50	951703	951715	951805	951817	951727	951829
7.17	951704	951716	951806	951818	951728	951830

*16" gearing

Yoke Selection Guide

(when using Hybrid Diff. Carrier)

34D/D380 and D340/380/400 carrier assemblies can be replaced by *new* 0341/381/401/402 carrier assemblies. These *new* carriers contain old straight spline side gears (except 400 and 401 series which use the same side gears).

New yokes (shown below) are required to use the *new* carrier. With your old yokes removed, measure the dimensions shown and choose new yokes to match your old yoke dimensions.

PLEASE REVIEW INFORMATION ON TOP OF PAGE 25 BEFORE ORDERING YOKE & SLINGERS.

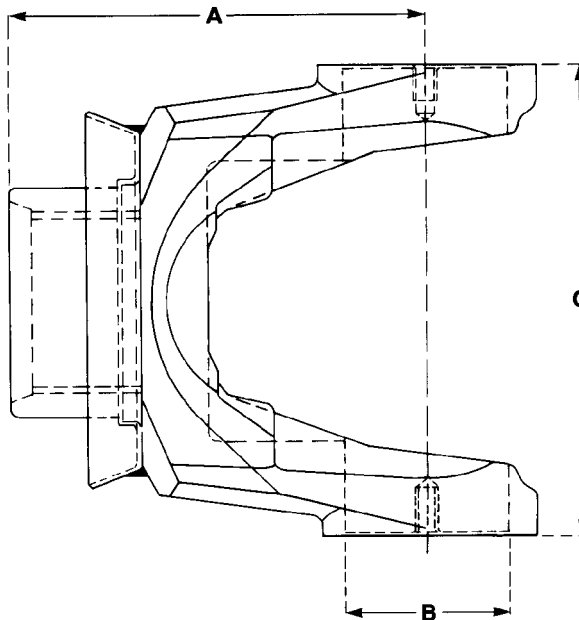

Forward Axle

	Old A Dim.	A Dim.	B Dim.	C Dim.	Part Number
Input w/mudslinger - 44 involute splines					
1710		5.190"	1.939"	6.093"	127754
1760		5.250"	1.939"	7.001"	127755
1810		5.250"	1.939"	7.551"	127753
Output w/mudslinger - 34 involute splines					
1610	4.748"	4.938"	1.876"	5.312"	127741
1610	6.000"	6.190"	1.876"	5.312"	127738
1710	5.250"	5.440"	1.939"	6.093"	127739
1710	6.123"	6.313"	1.939"	6.093"	127740

NOTE: The "A" Dimension on old-style output yokes will be .190" shorter because of the elimination of the rear bearing retaining washer on the new family of axles.

Rear Axle

	A Dim.	B Dim.	C Dim.	Part Number
Input w/mudslinger - 39 involute splines				
1610	4.718"	1.876"	5.312"	127746
1610	5.310"	1.876"	5.312"	127745
1610	6.000"	1.876"	5.312"	127743
1710	5.250"	1.939"	6.093"	127744
1710	6.125"	1.939"	6.093"	127742

NOTE: The "A" Dimension on old-style output yokes will be .190" shorter because of the elimination of the rear bearing retaining washer on the new family of axles.

Wheel Differential Kits

NEW!

Wheel Diff. Side Pinion Kit which contains spider, side pinions, side gear thrust washers, and side pinion thrust washers.

With this one kit - 118748 - and loose side gears, you can service all three generations of highway tandems.

Wheel Diff. Side Pinion Kit

Wheel Diff. Kits (Includes Side Gear, Side Pinions, Thrust Washers & Spider)

NEW! Kit No.	Axle Model	Side Gear	Spline Info.	
118748	34, 340 Series	37072	16 Str.	98850
(contains:	341 Series	110525	39 Inv.	114469
side pinion 104139,	38, 380 Series	37069	16 Str.	85358
spider 38289,	381 Series	110527	41 Inv.	114470
and thrust washers	400, 401 Series	85486	33 Inv.	98853
27810 and 27827)				



SPICER®

Drivetrain Products

Axles
Driveshafts
Off-Highway Transmissions

LONG®

Thermal Products

Transmission Oil Coolers
Engine Oil Coolers

VICTOR REINZ®

Sealing Products

Gaskets and Seals
Cylinder-Head Cover Modules
Thermal-Acoustic Protective Shielding



Dana Aftermarket Group
PO Box 321
Toledo, Ohio 43697-0321

Warehouse Distributors: 1.800.621.8084
OE Dealers: 1.877.777.5360

www.spicerparts.com

SPICER®

